

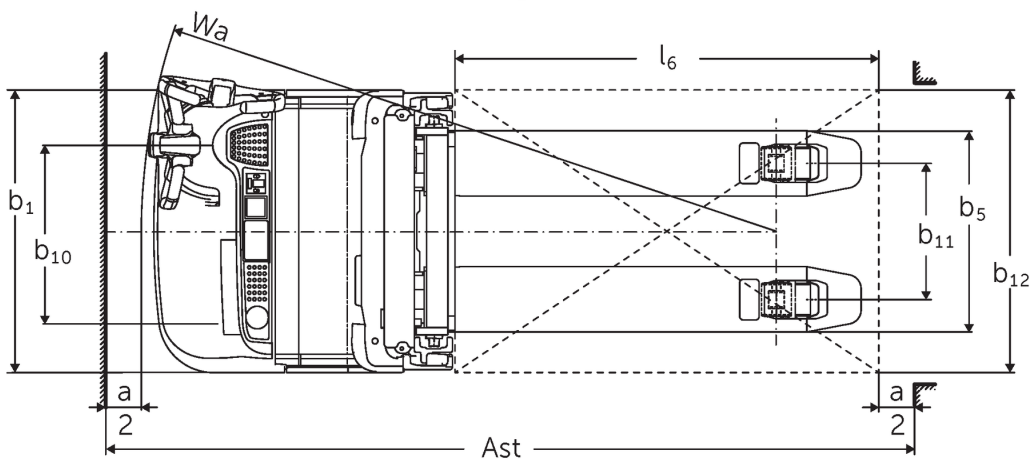

Electric pedestrian stacker **EJC 112z**

Lift height: 2500-4700 mm / Load capacity: 1200 kg

EJC 112z

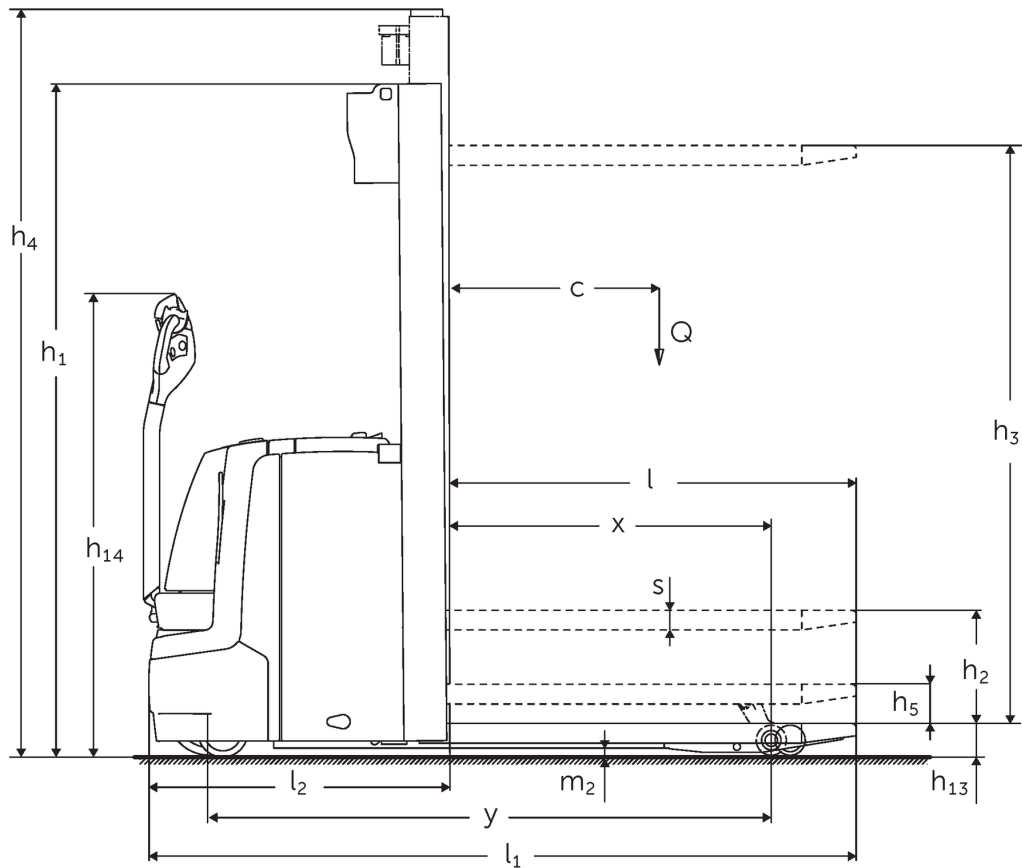

EJC 112z

EJC 112z	Lift (h3)	Retracted mast height (h1)	Free lift (h2)	Extended mast height (h4)
Duplex mast ZT	2500 mm	1750 mm	100 mm	2975 mm
	2700 mm	1850 mm	100 mm	3175 mm
	2900 mm	1950 mm	100 mm	3375 mm
	3200 mm	2100 mm	100 mm	3675 mm
	3600 mm	2300 mm	100 mm	4075 mm
	4100 mm	2550 mm	100 mm	4575 mm
	4300 mm	2650 mm	100 mm	4775 mm
Duplex mast ZZ	2500 mm	1700 mm	1225 mm	2975 mm
	2900 mm	1900 mm	1425 mm	3375 mm
	3200 mm	2050 mm	1575 mm	3675 mm
	3600 mm	2250 mm	1775 mm	4075 mm
	4100 mm	2500 mm	2025 mm	4575 mm
	4300 mm	2600 mm	2125 mm	4775 mm
Triplex mast DZ	4090 mm	1845 mm	1338 mm	4597 mm
	4300 mm	1915 mm	1408 mm	4807 mm
	4700 mm	2050 mm	1543 mm	5207 mm

VDI table

Stand-on: 11/2021

Characteristic	1.1	Manufacturer (abbreviated description)		Jungheinrich	
	1.2	Manufacturer's type designation		EJC 112z	
	1.3	Drive		Electric	
	1.4	Operation		Pedestrian	
	1.5	Load capacity/load	Q	kg	1200
	1.5.1	Rated capacity/load with mast lift	Q	kg	1200
	1.5.2	Rated capacity/load with support arm lift	Q	kg	2000
	1.6	Load centre distance	c	mm	600
	1.8	Load distance, centre of drive axle to fork	x	mm	910
	1.9	Wheelbase	y	mm	1502
Weights	2.1.1	Service weight (incl. battery)		kg	980
	2.2	Axle load laden front/rear		kg	965 / 1215
	2.3	Axle load unladen front/rear		kg	707 / 273
Wheels/suspension system	3.1	Tyres			Polyurethane (PU)
	3.2	Tyre size, front			Ø 230 x 70
	3.3	Tyre size, rear			Ø 85 x 95 /75
	3.4	Additional wheels			Ø 140 x 54
	3.5	Wheels, number front/back (x=driven)			1x + 1/2
	3.6	Tread width, front	b ₁₀	mm	507
	3.7	Tread width, rear	b ₁₁	mm	415
Basic dimensions	4.2	Retracted mast height (h1)	h ₁	mm	1950
	4.3	Free lift (h2)	h ₂	mm	100
	4.4	Lift (h3)	h ₃	mm	2880
	4.5	Extended mast height (h4)	h ₄	mm	3375
	4.6	Initial lift	h ₅	mm	122
	4.9	Height of tiller handle in drive position min./max.		mm	850 / 1305
	4.15	Height, lowered	h ₁₃	mm	90
	4.19	Overall length	l ₁	mm	1933
	4.20	Length including fork shank	l ₂	mm	783
	4.21.1	Overall width	b ₁	mm	800
	4.22	Fork dimensions	s/e/l	mm	56 x 185 x 1150
	4.25	Width across forks	b ₅	mm	570
	4.32	Ground clearance centre of wheelbase	m ₂	mm	20
	4.34	Aisle width (pallet 1000x1200 sideways)	Ast	mm	2168
	4.34.1	Aisle width (pallet 800x1200 length)	Ast	mm	2267
4.35	Turning radius	W _a	mm	1728	
Performance data	5.1	Travel speed laden/unladen		km/h	6 / 6
	5.2	Lift speed laden/unladen		m/s	0.18 / 0.29
	5.3	Lowering speed laden/unladen		m/s	0.49 / 0.39
	5.8	Max. gradeability laden/unladen		%	8 / 16
	5.10	Service brake			generative
E-motor/ Electronics	6.1	Drive motor, performance S2 60 min		kW	1
	6.2	Lift motor, performance with S3		kW	3
	6.3	Battery according to DIN 43531/35/36			A
	6.4	Battery voltage/nominal capacity		V / Ah	24 / 200
	6.5	Battery weight		kg	185

	6.6.1	Energy consumption according to EN cycle	kWh/h	0.66
	6.6.2	CO2 equivalent as per EN 16796	kg/h	0.4
Other	8.1	Type of drive control		AC
	10.7	Sound level as per EN12053, operator's ear	dB (A)	64
- This data sheet according to VDI guideline 2198 only states the technical values of the standard truck. Different tyres, other masts, additional equipment etc. may result in different values.				

Values for battery room S-VBE, mast ZT2900, 200 Ah battery, wheel arms raised.

- VDI no. 1.5: In double-decker operation (optional): mast lift max. 0.6 t / total load max. 2.0 t.
- VDI no. 1.5.1: In double-decker operation (optional): mast lift max. 0.6 t / total load max. 2.0 t.
- VDI no. 1.5.2: In double-decker operation (optional): mast lift max. 0.6 t / total load max. 2.0 t.
- VDI no. 1.8: With DZ mast: x - 42 mm. With lowered support arms: x + 54 mm.
- VDI no. 1.9: With battery compartment M-VBE or M Li-Ion: y + 69 mm. With lowered support arms: y + 54 mm.
- VDI no. 4.19: With DZ mast: l1 + 42 mm, with battery compartment M-VBE or M Li-Ion: l1 + 69 mm.
- VDI no. 4.20: With DZ mast: l2 + 42 mm, with battery compartment M-VBE or M Li-Ion: l2 + 69 mm.
- VDI no. 4.34: With battery compartment M-VBE or M Li-Ion: Ast + 69 mm. Diagonal according to VDI: + 368 mm. With DZ mast: Ast + 42 mm.
- VDI no. 4.34.1: With battery compartment M-VBE or M Li-Ion: Ast + 69 mm. Diagonal according to VDI: + 204 mm. With DZ mast: Ast + 42 mm.
- VDI no. 4.35: With battery compartment M-VBE or M Li-Ion: Wa + 69 mm. With lowered support arms: Wa + 54 mm.
- VDI no. 6.2: With S3 6%.

The German production facilities in
Norderstedt, Moosburg and Landsberg
are certified.

ISO 9001
ISO 14001

Jungheinrich fork lift trucks meet
European safety requirements.



 **JUNGHEINRICH**