

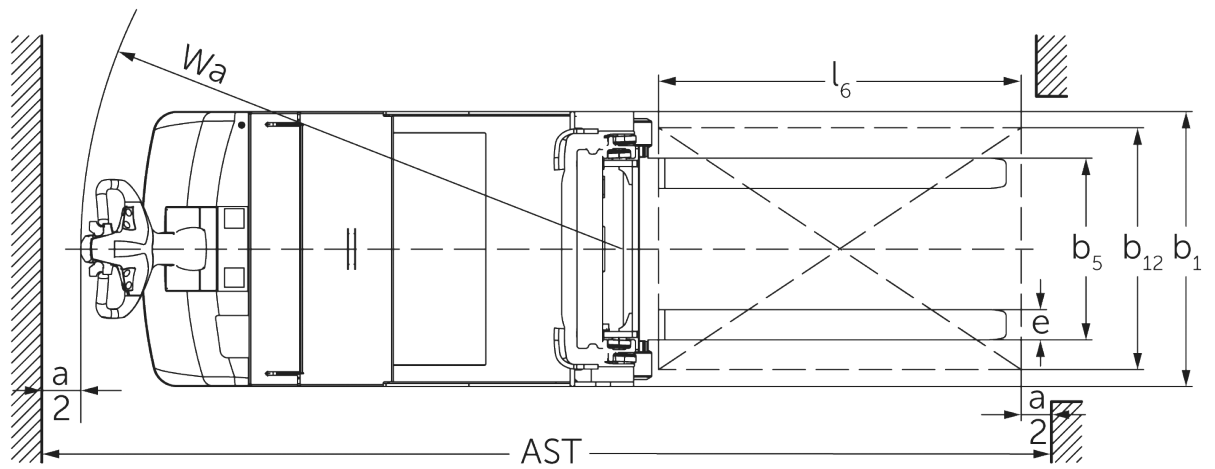

## **Cantilever electric pedestrian stacker** **EJK 212-216**

**Lift height: 2400-5350 mm / Load capacity: 1200-1600 kg**

# EJG 212-216

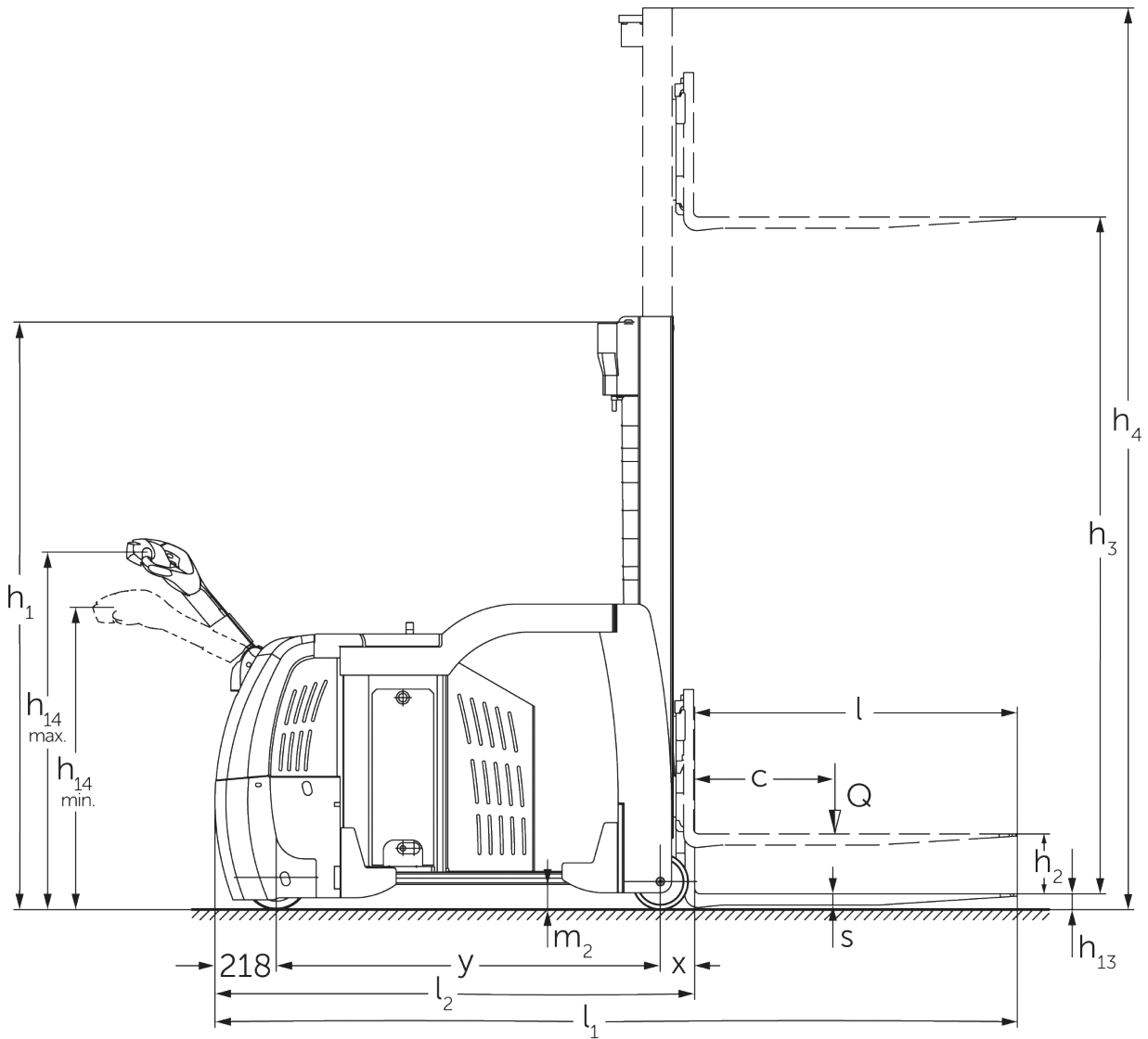

# EJG 212-216

<b>EJG 212</b>	<b>Lift (h3)</b>	<b>Retracted mast height (h1)</b>	<b>Free lift (h2)</b>	<b>Extended mast height (h4)</b>
Duplex mast ZT	<b>2500 mm</b>	<b>1965 mm</b>	<b>100 mm</b>	<b>3285 mm</b>
	2700 mm	2065 mm	100 mm	3485 mm
	2900 mm	2165 mm	100 mm	3685 mm
	3200 mm	2315 mm	100 mm	3985 mm
	3600 mm	2515 mm	100 mm	4385 mm
Duplex mast ZZ	<b>2500 mm</b>	<b>1915 mm</b>	<b>1225 mm</b>	<b>3285 mm</b>
	2900 mm	2115 mm	1425 mm	3685 mm
	3200 mm	2265 mm	1575 mm	3985 mm
	3600 mm	2465 mm	1775 mm	4290 mm
Triplex mast DZ	<b>4300 mm</b>	<b>2130 mm</b>	<b>1430 mm</b>	<b>5085 mm</b>
	4700 mm	2265 mm	1565 mm	5490 mm
<b>EJG 214</b>	<b>Lift (h3)</b>	<b>Retracted mast height (h1)</b>	<b>Free lift (h2)</b>	<b>Extended mast height (h4)</b>
Duplex mast ZT	<b>2500 mm</b>	<b>1965 mm</b>	<b>100 mm</b>	<b>3285 mm</b>
	2700 mm	2065 mm	100 mm	3485 mm
	2900 mm	2165 mm	100 mm	3685 mm
	3200 mm	2315 mm	100 mm	3985 mm
	3600 mm	2515 mm	100 mm	4385 mm
	4100 mm	2765 mm	100 mm	4885 mm
	4300 mm	2865 mm	100 mm	5085 mm
Duplex mast ZZ	<b>2500 mm</b>	<b>1915 mm</b>	<b>1130 mm</b>	<b>3285 mm</b>
	2900 mm	2115 mm	1330 mm	3685 mm
	3200 mm	2265 mm	1480 mm	3985 mm
	3600 mm	2465 mm	1680 mm	4385 mm
	4100 mm	2715 mm	1930 mm	4885 mm
	4300 mm	2815 mm	2030 mm	5085 mm
Triplex mast DZ	<b>4090 mm</b>	<b>2045 mm</b>	<b>1260 mm</b>	<b>4875 mm</b>
	4300 mm	2115 mm	1330 mm	5085 mm
	4690 mm	2245 mm	1460 mm	5475 mm
	5350 mm	2465 mm	1680 mm	6135 mm
<b>EJG 216</b>	<b>Lift (h3)</b>	<b>Retracted mast height (h1)</b>	<b>Free lift (h2)</b>	<b>Extended mast height (h4)</b>
Duplex mast ZT	<b>2400 mm</b>	<b>1965 mm</b>	<b>100 mm</b>	<b>3185 mm</b>
	2600 mm	2065 mm	100 mm	3385 mm
	2800 mm	2165 mm	100 mm	3585 mm
	3100 mm	2365 mm	100 mm	3885 mm
	3500 mm	2515 mm	100 mm	4285 mm
	3800 mm	2665 mm	100 mm	4585 mm
	4000 mm	2765 mm	100 mm	4785 mm
	4200 mm	2865 mm	100 mm	4985 mm
Duplex mast ZZ	<b>2400 mm</b>	<b>1915 mm</b>	<b>1130 mm</b>	<b>3185 mm</b>
	2800 mm	2115 mm	1330 mm	3585 mm
	3100 mm	2265 mm	1480 mm	3885 mm
	3500 mm	2465 mm	1680 mm	4285 mm
	4000 mm	2715 mm	1930 mm	4785 mm
	4200 mm	2815 mm	2030 mm	4985 mm
Triplex mast DZ	<b>3990 mm</b>	<b>2045 mm</b>	<b>1260 mm</b>	<b>4775 mm</b>
	4200 mm	2115 mm	1330 mm	4985 mm
	4590 mm	2245 mm	1460 mm	5375 mm

5250 mm

2465 mm

1680 mm

6035 mm

# VDI table

Stand-on: 11/2021

Characteristic	No.	Description	Unit	Jungheinrich		
				EJG 212	EJG 214	EJG 216
Characteristic	1.1	Manufacturer (abbreviated description)		Jungheinrich		
	1.2	Manufacturer's type designation		EJG 212	EJG 214	EJG 216
	1.3	Drive		Electric		
	1.4	Operation		Pedestrian		
	1.5	Load capacity/load	Q kg	1200	1400	1600
	1.6	Load centre distance	c mm	500		
	1.8	Load distance, centre of drive axle to fork	x mm	120		
	1.9	Wheelbase	y mm	1130	1250	1370
	Weights	2.1.1	Service weight (incl. battery)	kg	2275	2285
2.2		Axle load laden front/rear	kg	685 / 2790	685 / 3000	685 / 3210
2.3		Axle load unladen front/rear	kg	1340 / 935	1375 / 910	1410 / 885
Wheels/suspension system	3.1	Tyres		Polyurethane (PU)		
	3.2	Tyre size, front		Ø 230 x 100		
	3.3	Tyre size, rear		Ø 200 x 100		
	3.5	Wheels, number front/back (x=driven)		1x / 2		
	3.7	Tread width, rear	b <sub>11</sub> mm	764		
Basic dimensions	4.2	Retracted mast height (h1)	h <sub>1</sub> mm	2165		
	4.3	Free lift (h2)	h <sub>2</sub> mm	100		
	4.4	Lift (h3)	h <sub>3</sub> mm	2800		
	4.5	Extended mast height (h4)	h <sub>4</sub> mm	3585		
	4.9	Height of tiller handle in drive position min./max.	mm	1080 / 1275		
	4.15	Height, lowered	h <sub>13</sub> mm	70		
	4.19	Overall length	l <sub>1</sub> mm	2630	2750	2870
	4.20	Length including fork shank	l <sub>2</sub> mm	1480	1600	1720
	4.21.1	Overall width	b <sub>1</sub> mm	910		
	4.22	Fork dimensions	s/e/l mm	40 x 80 x 1150		
	4.23	Fork carriage connection class		2B		
	4.24	Fork carriage width	b <sub>3</sub> mm	680		
	4.25	Width across forks	b <sub>5</sub> mm	580		
	4.32	Ground clearance centre of wheelbase	m <sub>2</sub> mm	90		
	4.34.1	Aisle width (pallet 800x1200 length)	Ast mm	3210	3330	3450
	4.35	Turning radius	W <sub>a</sub> mm	1630	1750	1870
Performance data	5.1	Travel speed laden/unladen	km/h	6 / 6		
	5.2	Lift speed laden/unladen	m/s	0.15 / 0.25		
	5.3	Lowering speed laden/unladen	m/s	0.37 / 0.34		
	5.8	Max. gradeability laden/unladen	%	5 / 9		
	5.10	Service brake		electric		
E-motor/ Electronics	6.1	Drive motor, performance S2 60 min	kW	2.8		
	6.2	Lift motor, performance with S3	kW	3		
	6.4	Battery voltage/nominal capacity	V / Ah	24 / 375		
	6.5	Battery weight	kg	306		
Other	8.1	Type of drive control		AC		

- This data sheet according to VDI guideline 2198 only states the technical values of the standard truck. Different tyres, other masts, additional equipment etc. may result in different values.

- VDI no. 4.22: fork carrier ISO 2328, type 2B

The German production facilities in  
Norderstedt, Moosburg and Landsberg  
are certified.

ISO 9001  
ISO 14001

Jungheinrich fork lift trucks meet  
European safety requirements.



 **JUNGHEINRICH**

The Jungheinrich logo, featuring a red upward-pointing arrow above the word 'JUNGHEINRICH' in a bold, black, sans-serif font.